

# Wrist Pulse Signal Monitoring System

Dharshan<sup>1</sup> and Suguna G C<sup>2</sup>

<sup>1</sup>Students of ECE Department, JSSATE, Bangalore  
darshandheerendra@gmail.com

<sup>2</sup>Assistant Professor of ECE Department, JSSATE, Bangalore  
Sgc.mtech2006@gmail.com

**Abstract**— Diagnosis is an important tool presented by ayurveda which is to find the root cause of the disease. It has been observed that it is much easier to determine the pulse of a person with three fingers than by one. Nadipariksha [1] is the oldest ayurvedic technique of diagnosis through the pulse. It is a non-invasive method to determine the disease. Nadi gets influenced by various affects that determine the physiology of the body especially the three doshas Vata, Pitta and Kapha. Vata is measured by index finger, Pitta is measured by middle finger and Kapha is measured by ring finger. These pulses are measured on the radial artery of the patient. Presently this technique is objective in nature. Hence, wrist pulse detection system is therefore developed to provide support to ancient system. Pressure sensor is used for pulse detection. The pulse signals obtained are then amplified by amplifier circuit. The amplified signal is then fed to ARM M7 microcontroller to remove negative values and digitize the analog signal which is interfaced with LCD and analysis of waveform is performed on personal computer. Pulse shapes, rates, amplitude are stored and found to be different for different people having different doshas. The three pulses represent different shapes and different frequencies.

**Index Terms**— Pulse Diagnosis, Nadi vigyana, Pressure sensor, Human Pulse, Vata, Pitta, Kapha, Nadipariksha.

## I. INTRODUCTION

Ayurvedic [2] pulse measurement is done by placing index, middle and ring finger on the wrist. Pulse can be measured in the superficial middle and deep levels thus obtaining more information regarding energy imbalance of the patient. In Traditional Chinese medicine, the pulse is divided into three positions on each wrist. Other approaches focus on individual pulse positions, looking at changes in the pulse quality and strength within the position with each position having an association with a particular body area. Ayurveda supports health without disturbing the natural intelligence of the body. Ayurvedic therapy and methods have no effects. As a result, people around the world are now turning towards this science to provide support people and maintain good health. Hence, we need to design an system to support the cause of benefits to the existing methods for pulse. Traditional Indian Medicine [6] and Traditional Chinese Medicine remains the most ancient and oldest living styles. The Researchers and ministry of chemicals has undergone the importance of traditional knowledge. Presently, the method used was subjective and the accuracy of the pulse is depended on examiner. Now the first step towards the approach is Nadi diagnosis an objective human pulse monitoring system has been designed.



Figure 1. Traditional Pulse Diagnosis Method

## II. SYSTEM ARCHITECTURE

The pulse pressure signals are measured on radial artery follows a specific criterion. The following method provides the design and development of system. In the first step the block is shown below.

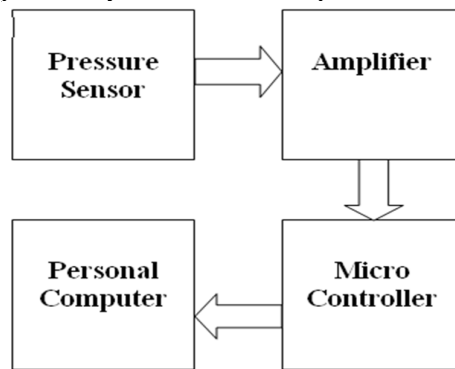

Figure 2. Block Diagram of the System

## III. COMPONENTS AND EQUIPMENTS

System components consist of sensor unit, amplifier unit ARM M7 microcontroller and personal computer.

### A. Pressure Sensor



Figure 3. MPS2000 Pressure Sensor

The MPS-2000 features silicon pressure sensors in 6-pin dual in-line packages. All parts in these series are uncompensated high-performance die mounted on a substrate with a plastic cap. The MPS-2000 is ideal for

applications requiring low hysteresis, high reliability and stability. With constant voltage excitation, the MPS-2000[7] produces a voltage output that is linearly proportional to the input pressure. The user can provide MPS-2000 with signal conditioning circuitry to amplify the output signal or to maximize OEM value added. The MPS-2000 is compatible with most noncorrosive gases and dry air.

### B. Amplifier/Filter

The AD8232 [8] is an integrated signal conditioning device for ECG pulse and other measurement applications. It was designed to remove the noise which arises due to movement or remote electrode position present in the wrist pulse and to amplify wrist pulses for further analysis. It can also be used as a two-pole high pass filter for eliminating motion artifacts and the electrode half cell potential. It includes an effective function that suppresses the duration of pulse otherwise leading to improper match of frequency response of high pass filters. This characteristic provides AD8232 to obtain valid measurements soon after connecting the electrodes to the person.

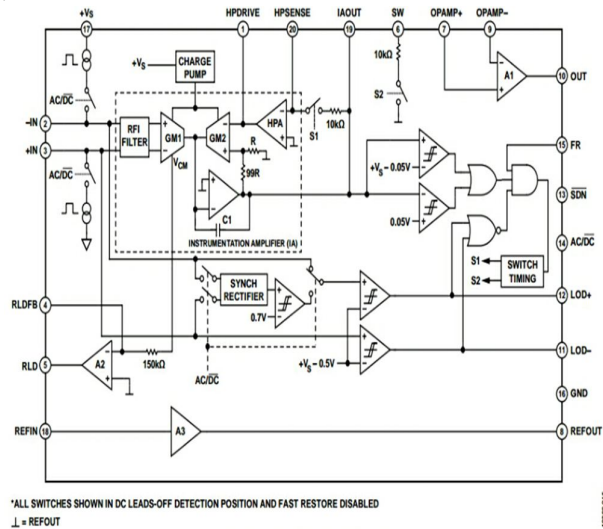

Figure 4. Instrumentation amplifier

### C. Microcontroller



Figure 5. LPC2148 Controller

The ARM M7 LPC2148 [8] primer board is specifically designed to provide efficient interface with 32 bit microcontroller. ARM M7 is most successful processor in embedded applications. It is preloaded with many in built features and applications.

The features of LPC2148 are:

- 12MHZ crystal for maximum (60MHZ) CPU clock
- 16/32 bit ARM7TDMI-S microcontroller in a tiny Package.

- Single 10 bit DAC provides variable analog output.

#### IV. RESULTS AND DISCUSSION

Large samples of human pulse are obtained and analyzed using matlab tool which provides detail study of the system.

##### A. Recording of Signal

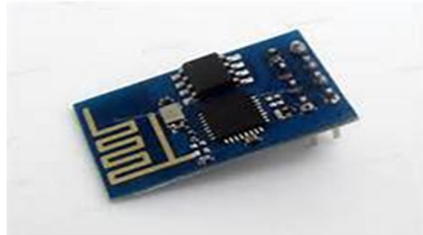

Figure 6. ESP8266 Wi-Fi Module

The fact that motivated for the designing of the system was to store the pulse and process it offline. To achieve this operation, we use Wi-Fi module ESP8266. The ESP8266 Wi-Fi Module is a self-contained block with inbuilt TCP/IP protocol stack that enables any microcontroller to connect to any Wi-Fi network. The ESP8266 is strong enough to establish an application or offloading all Wi-Fi networking tasks from another application processor. Each ESP8266 kit is available in preprogrammed environment with an AT command set software in the sense, we can directly connect this to our ARM M7 device and get results. The ESP8266 module is an extremely cost-effective board with large and effective in cost price.

The pulses were examined and analyzed at different situations and at different environment. As wrist signals are too weak nature there amplified and filtered to reduce noise. The signals are then determined for different cases vata dominant, pitta dominant, kapha dominant. The pulse repetition rates too have been found on different subjects which is verified as that given by nadi Vaidya. The three different frequency bands are noted for three different subjects. The ADC values are sent through Wi-Fi where it is stored in things big which is a software to hold the offline storage of data.

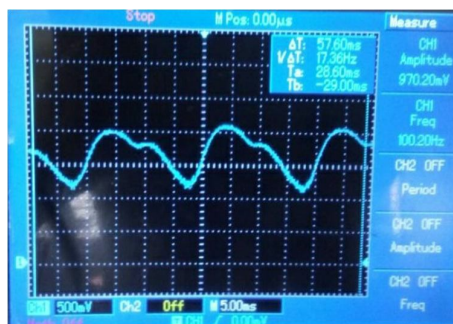

Figure 7(a). Kapha pulse

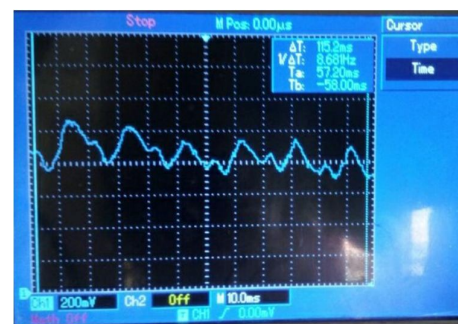

Figure 7(b). Pitta pulse

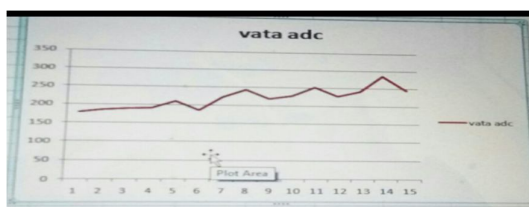

Figure a. Vata ADC waveform

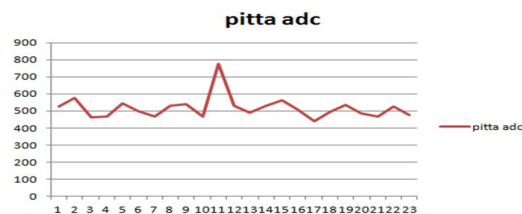

Figure b. Pitta ADC waveform

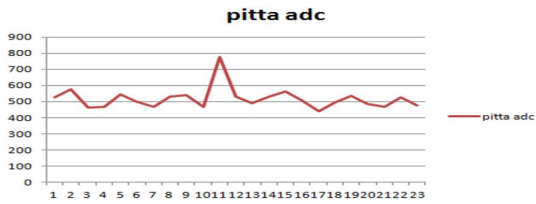

Figure c. Pitta ADC waveform

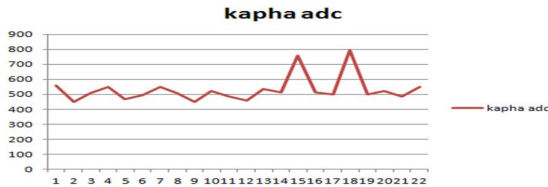
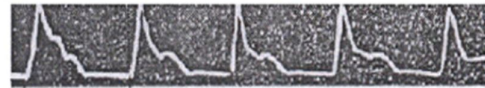

Figure d. Kapha ADC waveform



(d) *Vata* pulse



(e) *Pitta* pulse



(f) *Kapha* pulse

Figure . 7(a),7(b),7(c) are ADC waveform of pulse,7(d),7(e),7(f) Standard waveforms respectively.

The recorded pulse can be viewed using CRO (digital oscilloscope) for further accurate analysis where it can be only performed instantaneously to measure all the parameters of the signal. While measuring the pulse the patients should be sitting on the chair and patients hand should be in steady position. The recorded pulse as shown in figure 7(a),7(b) and 7(c) are being compared with standard waveforms are observed and inference has been made.

## V. CONCLUSION

A system to detect human pulse and monitoring has been developed successfully and compared with standard pulse waveforms and data provided by Nadi-Vaidya. This system can be further useful for characterizing the disease in detail based on doshas. Frequency domain and time domain analysis are the two-basic analysis procedure involved.

## REFERENCES

- [1] Medha Sanjeev Dhurandhar, Girish Shrikrishna, "Diagnostic Classifications of Pulse signal waveform data", United States Patent Application Publication, Pub. No.:US 2012/0183861 A1, Pub.Date:19,2012.
- [2] S. Upadhyaya, "NadiVijnana - Ancient Pulse Science", Chaukhamba Sanskrit Pratishthan.
- [3] An essay on "Traditional Pulse Diagnosis" by Subhuti Dharmanandana, Director, Institute for Traditional Medicine, Portland.
- [4] J Bukdon Sandeason, "Handbook of the Sphygmograph", Spottiswoode and Co.New Street Square,London.
- [5] Peng Wang, WangmengZuo and David Zhang, "A Compound Pressure Signal Acquisition System for Multichannel Wrist Pulse Signal Analysis", IEEE Transactions on Instrumentation & Measurement, Vol. 63, No. 6, June 2013.
- [6] Tianyu Fu, "Pulse Reading Mobile Application:Dr. Chi", Electrical Engineering and Computer SciencesUniversity of California at Berkeley, Technical Report Number UCB/EECS-2012-150, June 1, 2012.
- [7] MPS 2000 DIP PRESSURE SENSOR.
- [8] ARM CORTEX M7 TECHNICAL PROCESSOR ARM INFOTECH.  
[http://infocenter.arm.com/help/topic/com.arm.doc.ddi0489b/DDI0489B\\_cortex\\_m7\\_trm.pdf](http://infocenter.arm.com/help/topic/com.arm.doc.ddi0489b/DDI0489B_cortex_m7_trm.pdf).